

Step 1: Making rib 'Stern-A'

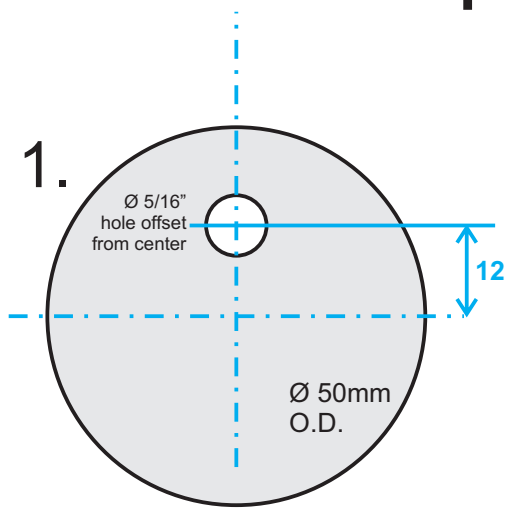

1. Cut 50mm disk from 0.080" plastic. Drill 5/16" hole offset from center by 12mm as shown.

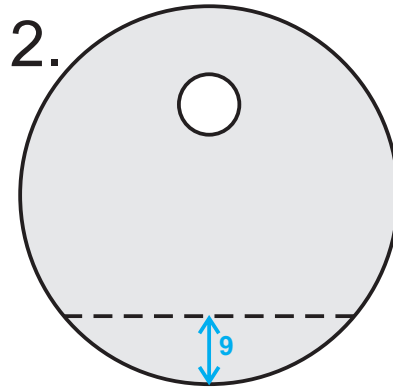

2. Cut off 9mm-high segment as shown. Do not discard.

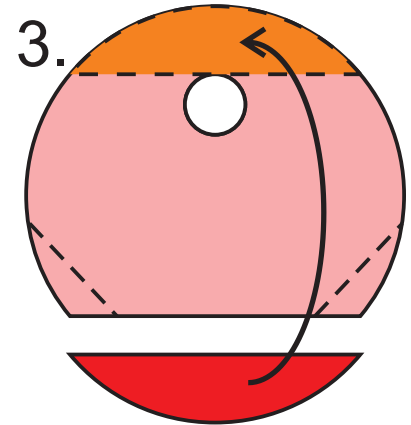

3. Glue the previously-cut segment to the other side as shown, edges flush.

Cut 2 angled sections from sides as shown, and discard.

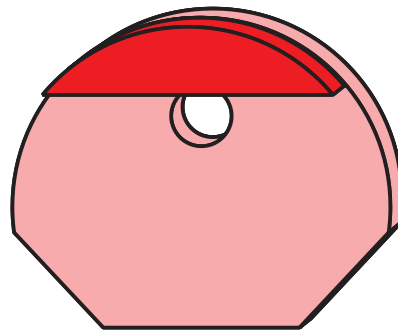
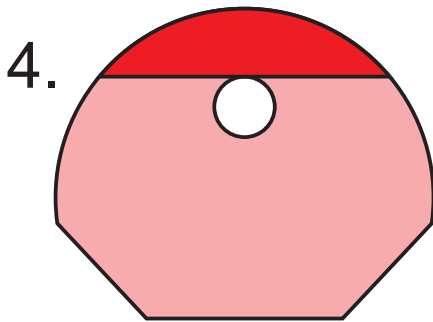

4. Completed rib 'Stern-A'

Step 2: Making rib 'Stern'

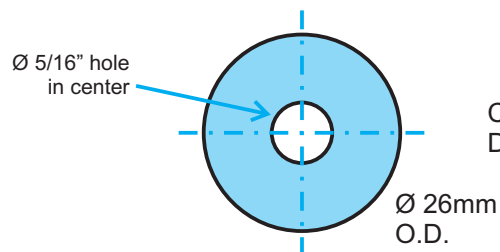

- Cut 26mm disk from 0.080" plastic. Drill 5/16" hole in center.

Ø 26mm
O.D.

Step 3: Assembling 'Stern'

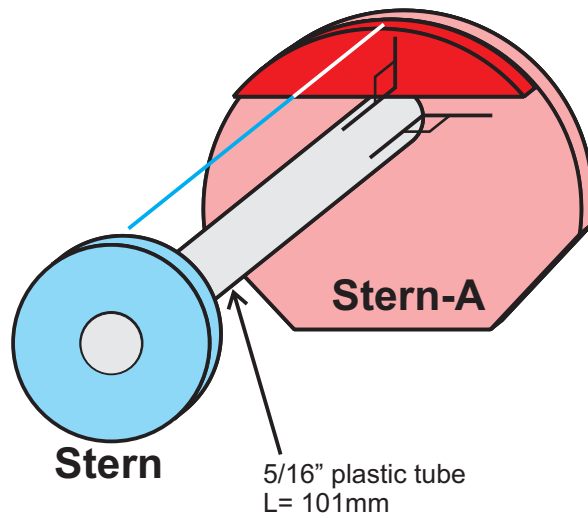
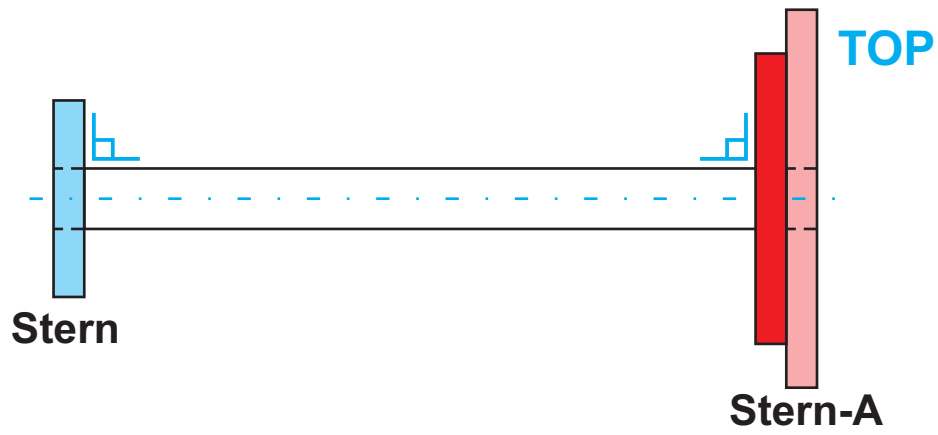
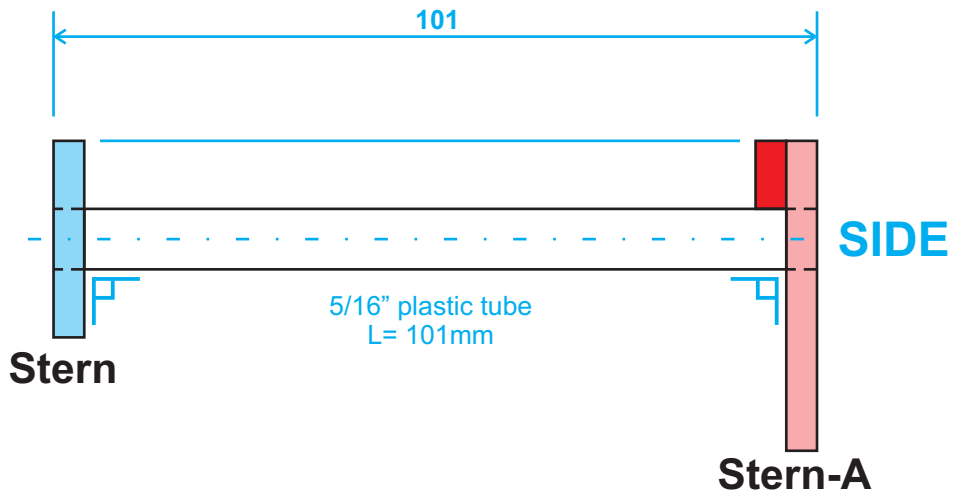

Step 4: Skinning 'Stern'

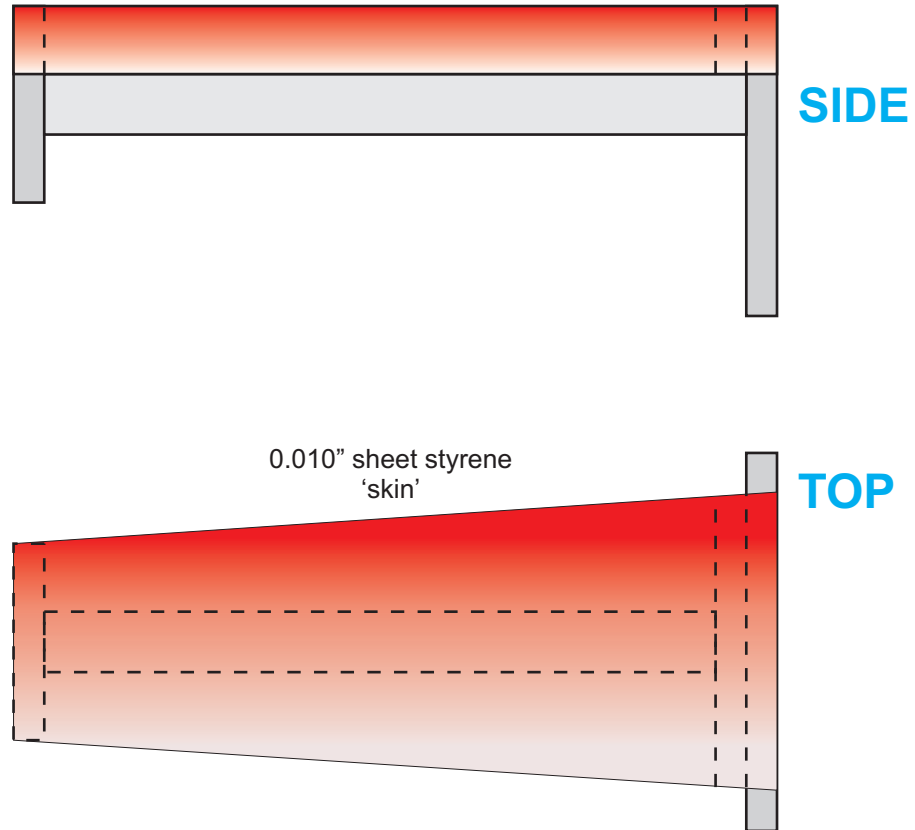

Step 5: Installing 'Stern'

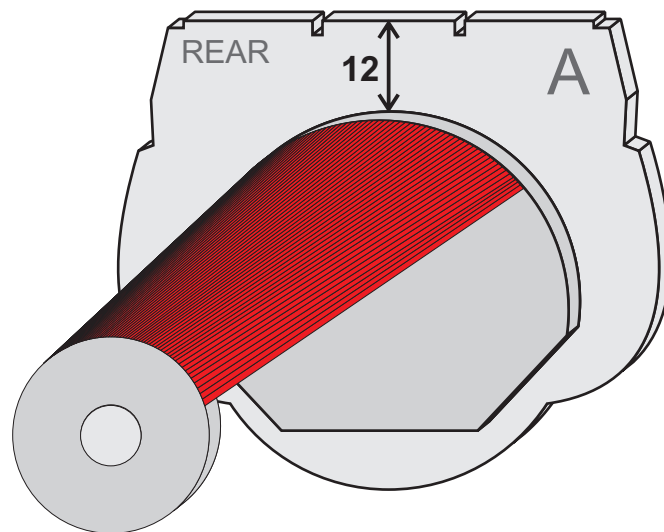

Glue the entire 'Stern' assembly to the rear of bulkhead A, so the top center of rib 'Stern-A' is 12mm from top of the bulkhead.